

*An Online CPD Course  
brought to you by  
CEDengineering.ca*

## **Parking Lot Design**

Course No: C04-066

Credit: 4 PDH

---

Najib Gerges, Ph.D., P.E.

---

**CED** CANADA  
engineering.ca  
CPD FOR THE PROFESSIONAL

Continuing Education and Development, Inc.

P: (877) 322-5800

[info@cedengineering.ca](mailto:info@cedengineering.ca)

[www.cedengineering.ca](http://www.cedengineering.ca)

## Table of Contents

List of Figures.....	iii
Section 1 — General.....	1
General Considerations .....	1
Pedestrian and Vehicular Circulation .....	1
Access to Parking Areas.....	2
Handicapped Accessible Parking Spaces .....	2
Driveway Entrance Design.....	2
Section 2 — Parking Lot Design (Layout).....	2
Overview.....	2
Types of Parking Facilities .....	3
On-Street Parking Facilities .....	3
Off-Street Parking Facilities.....	3
Definitions of Parking Terms .....	3
Methodology of Parking Studies .....	4
Inventory of Existing Parking Facilities .....	4
Collection of Parking Data .....	5
Analysis of Parking Data .....	8
Design of On-Street Parking Facilities .....	9
Design of Off-Street Parking Facilities .....	11
Design of Off-Street Parking Facilities—Garages .....	14
General Considerations .....	14
Section 3 — Parking Lot Drainage Design .....	16
General Considerations .....	16
Drainage Provisions.....	17
Curb and Gutter.....	18
Section 4 — Parking Lot Pavement Design.....	18
Asphalt Surface Course.....	18
Tack Coat .....	19
Pavement Surface Sealants .....	19

---

Base Construction (Asphalt) .....	19
Base Construction (Aggregate).....	19
Subgrade Preparation.....	20
Truck Lanes for Loading, Dumpsters, etc. ....	20
Pavement Structure.....	21
Future Maintenance Considerations.....	23
Section 5 — Miscellaneous Design Considerations.....	23
Painting (Marking) and Striping.....	23
Layout .....	23
Painting (Marking) .....	23
Striping.....	24
Re-Striping .....	25
Bumpers and Stops.....	25
Purpose.....	25
Approved Barriers (Wheel Stops).....	25
Location .....	26
Painting/Marking.....	26
Benefits.....	27
Green Considerations.....	27
Porous Asphalt.....	27
Planting Strategies.....	28
Lighting .....	30
Purpose.....	30
Criteria .....	30
Luminaires .....	31
Landscaping of Parking Areas.....	33
General Guideline.....	33
Numerical Requirements.....	33
Design Requirements .....	33
Additional Considerations .....	34
Maintenance and Repair .....	36

Introduction..... 36  
Proper Drainage..... 36  
Inspection and Evaluation ..... 36  
Section 6 — References ..... 39

## List of Figures

Figure 1 Parking Accumulation at a Parking Lot..... 6  
Figure 2 The Spark Service System ..... 7  
Figure 3 Street Space Used for Various Parking Configurations ..... 11  
Figure 4 Parking Stall Layout ..... 12  
Figure 5 Herringbone Layout of Parking Stalls in an On-Surface Lot ..... 13  
Figure 6 Reservoir Space Required If Facility Is Overloaded Less Than One Percent of Time ..... 15  
Figure 7 Drainage Considerations ..... 16  
Figure 8 Cross-Section of Parking Lane (Urban Roadway) ..... 17  
Figure 9 Cross-Section of Parking Lane (Urban Roadway) ..... 17  
Figure 10 Full-Depth Asphalt Pavement (Parking Stall Areas) ..... 21  
Figure 11 Asphalt with Aggregate Sub-Base Pavement (Parking Stall Areas) ..... 21  
Figure 12 Full-Depth Asphalt Pavement (Truck/Bus Drive Lanes) ..... 22  
Figure 13 Asphalt with Aggregate Sub-Base Pavement (Truck/Bus Drive Lanes) ..... 22  
Figure 14 Accessible Space Marking..... 24  
Figure 15 Precast Concrete Parking Barrier ..... 25  
Figure 16 Parking Barrier Anchors..... 26  
Figure 17 Cutoff Light feature ..... 32  
Figure 18 Parking Additional Intermediate Islands ..... 34  
Figure 19 Minimum Clearance for Sight Lines..... 35  
Figure 20 Vehicular Encroachment at Existing Trees ..... 35

## Section 1 — General

### General Considerations

Great parking lots are safe, attractive, drain efficiently when it rains and are screened from residential areas. Striping and signage indicating regular and handicapped parking spaces, as well as direction of traffic flow, should be clearly marked. Safe pedestrian walkways, including easy access for wheelchairs, need to be separate from the traffic-flow areas. Landscaping that offers shade and visual relief while maintaining good sight lines is beneficial. In areas where it snows, good parking-lot planning also demands setting aside holding areas where snowplows can pile snow without blocking parking spaces or the flow of traffic.

Parking lot design involves many considerations. All too often the only consideration for the design is developing a sufficient parking area to meet the required number of vehicles based on adjacent occupancy. Local regulations generally dictate many of the planning and design decisions made by the planner or designer. This course presents ideas and methodologies for many concepts that could be inconsistent with these local requirements. Often, these ordinances are a minimum requirement and consideration can be given to other concepts.

Good parking lot maximizes the total number of parking spaces in the space available with the following considerations:

- The parking layout should provide continuous flow of traffic through the lot.
- There must be safe pedestrian movement from parking to buildings.
- The design should allow for appropriate landscaping of the parking areas without conflicting with the site lighting.

### Pedestrian and Vehicular Circulation

Circulation patterns should be as obvious and simple as possible. All likely pedestrian routes should be considered in the design phase to eliminate “short cuts” which will eventually damage landscaped areas. All site facilities and amenities should be accessible to people with disabilities. Circulation systems should be designed to avoid conflicts between vehicular, bicycle, and pedestrian traffic. Pedestrian circulation should take precedence over vehicular circulation. Where pedestrian circulation crosses vehicular routes, a crosswalk with yellow striping in plastic paint, speed bumps, or signage should be provided to emphasize the conflict point and improve its visibility and safety. Circulation routes should focus upon main entries and exits and also identify secondary access points. All elements of the site design should accommodate access requirements of emergency service vehicles.

### **Access to Parking Areas**

All off-street parking spaces should be accessible without backing into or otherwise re-entering a public right-of-way, unless it is physically impossible to provide for such access. When an off-street parking area does not abut a public street, there should be an access drive not less than 24 feet in width for two-way traffic, connecting the off-street parking area with a public street.

### **Handicapped Accessible Parking Spaces**

The location, size, and number of handicapped parking spaces should conform to the latest building codes, state and federal laws. Handicapped accessible parking spaces should be located on the shortest accessible route of travel to an accessible facility entrance. Where buildings have multiple accessible entrances with adjacent parking, the accessible parking spaces must be dispersed and located closest to the accessible entrances.

An accessible route must always be provided from the accessible parking to the accessible entrance. Ideally, an accessible route would not have curbs or stairs, and be at least three (3) feet wide, with a firm, slip-resistant surface.

Accessible parking spaces should be at least 102 inches wide. Parking access aisles should be part of an accessible route to the building or facility entrance. Two accessible parking spaces may share a common access aisle. Parked vehicle overhangs should not reduce the clear width of an accessible route.

### **Driveway Entrance Design**

The location of driveways is based upon many factors, including the location of individual property lines and available street frontage, requirements of internal site design, number of vehicles expected to use the driveways, and traffic safety. Generally, the farther from an intersection a driveway can be located, the less it will affect the through traffic and the less delay it will cause to vehicles using the driveway.

Driveway approaches should be constructed so as not to interfere with pedestrian crosswalks. Driveways should be constructed at a minimum of three (3) feet from any obstruction such as a street light or utility pole, fire hydrant, traffic signal controller, or telephone junction box. Driveway entrances should be designed to accommodate all vehicle types having access to enter the lot, including delivery and service vehicles.

## **Section 2 — Parking Lot Design (Layout)**

### **Overview**

Any vehicle traveling on a highway will at one time or another be parked for either a relatively short time or a much longer time, depending on the reason for parking. The provision of

parking facilities is therefore an essential element of the highway mode of transportation. The need for parking spaces is usually very great in areas where land uses include business, residential, or commercial activities. The growing use of the automobile as a personal feeder service to transit systems (“park-and-ride”) has also increased the demand for parking spaces at transit stations. In areas of high density, where space is very expensive, the space provided for automobiles usually has to be divided between that allocated for their movement and that allocated for parking them.

Providing adequate parking space to meet the demand for parking in the Central Business District (CBD) may necessitate the provision of parking bays along curbs which reduces the capacity of the streets and may affect the level of service. This problem usually confronts a city traffic engineer. The solution is not simple, since the allocation of available space will depend on the goals of the community which the traffic engineer must take into consideration when trying to solve the problem. Parking studies are therefore used to determine the demand for and the supply of parking facilities in an area, the projection of the demand, and the views of various interest groups on how best to solve the problem. Before the details of parking studies are discussed, it is necessary to discuss the different types of parking facilities.

### **Types of Parking Facilities**

Parking facilities can be divided into two main groups: on-street and off-street.

#### **On-Street Parking Facilities**

These are also known as curb facilities. Parking bays are provided alongside the curb on one or both sides of the street. These bays can be unrestricted parking facilities if the duration of parking is unlimited and parking is free, or they can be restricted parking facilities if parking is limited to specific times of the day for a maximum duration. Parking at restricted facilities may or may not be free. Restricted facilities also may be provided for specific purposes, such as to provide handicapped parking or as bus stops or loading bays.

#### **Off-Street Parking Facilities**

These facilities may be privately or publicly owned; they include surface lots and garages. Self-parking garages require that drivers park their own automobiles; attendant-parking garages maintain personnel to park the automobiles.

### **Definitions of Parking Terms**

Before discussing the different methods for conducting a parking study, it is necessary to define some terms commonly used in parking studies including space-hour, parking volume, parking accumulation, parking load, parking duration, and parking turnover.

*Space-Hour:* is a unit of parking that defines the use of a single parking space for a period of 1 hour.

*Parking Volume:* is the total number of vehicles that park in a study area during a specific length of time, usually a day.

*Parking Accumulation:* is the number of parked vehicles in a study area at any specified time. These data can be plotted as a curve of parking accumulation against time, which shows the variation of the parking accumulation during the day.

*Parking Load:* is the area under the accumulation curve between two specific times. It is usually given as the number of space-hours used during the specified period of time.

*Parking Duration:* is the length of time a vehicle is parked at a parking bay. When the parking duration is given as an average, it gives an indication of how frequently a parking space becomes available.

*Parking Turnover:* is the rate of use of a parking space. It is obtained by dividing the parking volume for a specified period by the number of parking spaces.

### **Methodology of Parking Studies**

A comprehensive parking study usually involves (1) inventory of existing parking facilities, (2) collection of data on parking accumulation, parking turnover and parking duration, (3) identification of parking generators, and (4) collection of information on parking demand. Information on related factors, such as financial, legal, and administrative matters, also may be collected.

#### **Inventory of Existing Parking Facilities**

An inventory of existing parking facilities is a detailed listing of the location and all other relevant characteristics of each legal parking facility, private and public, in the study area. The inventory includes both on- and off-street facilities. The relevant characteristics usually listed include the followings:

- Type and number of parking spaces at each parking facility.
- Times of operation and limit on duration of parking, if any.
- Type of ownership (private or public).
- Parking fees, if any, and method of collection.
- Restrictions on use (open or closed to the public).
- Other restrictions, if any (such as loading and unloading zones, bus stops, or taxi ranks).
- Probable degree of permanency (can the facility be regarded as permanent or is it just a temporary facility?) The information obtained from an inventory of parking facilities is useful both to the



traffic engineer and to public agencies, such as zoning commissions and planning departments. The inventory should be updated at regular intervals of about four to five years.

### Collection of Parking Data

*Accumulation:* Accumulation data are obtained by checking the amount of parking during regular intervals on different days of the week. The checks are usually carried out on an hourly or 2-hour basis between 6:00 a.m. and 12 midnight. The selection of the times depends on the operation times of land-use activities that act as parking generators. For example, if a commercial zone is included, checks should be made during the times when retail shops are open, which may include periods up to 9:30 p.m. on some days. On the other hand, at truck stops, the highest accumulation may occur around midnight which requires information to be collected at that time. The information obtained is used to determine hourly variations of parking and peak periods of parking demand. (Refer to Figure 1)

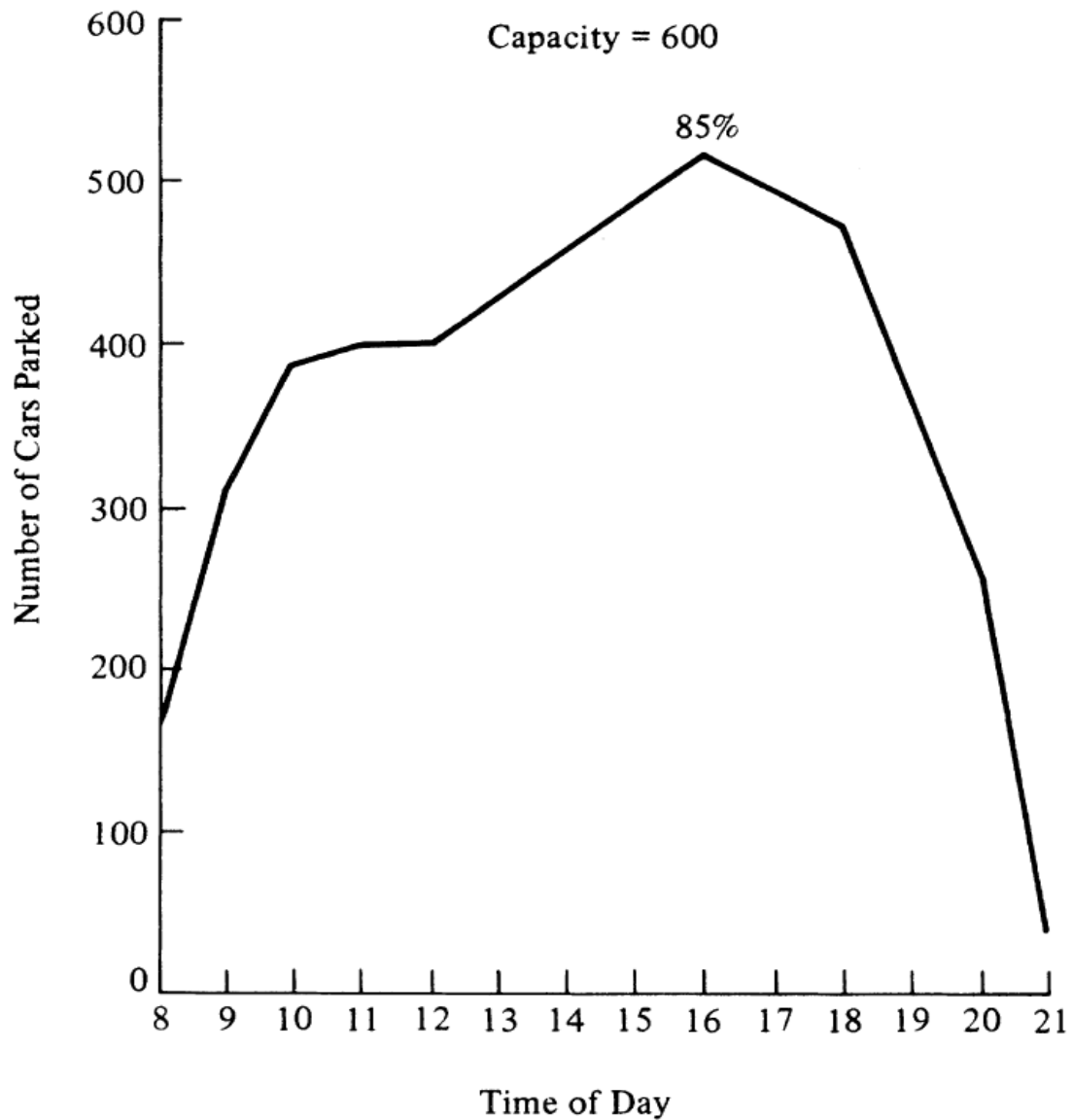

Figure 1 Parking Accumulation at a Parking Lot

*Turnover and Duration:* Information on turnover and duration is usually obtained by collecting data on a sample of parking spaces in a given block. This is done by recording the license plate of the vehicle parked on each parking space in the sample at the ends of fixed intervals during the study period. The length of the fixed intervals depends on the maximum permissible duration. For example, if the maximum permissible duration of parking at a curb face is 1 hour, a suitable interval is every 20 minutes. If the permissible duration is 2 hours, checking every 30 minutes would be appropriate. Turnover is then obtained from the equation:

$$T = \frac{\text{number of different vehicles parked}}{\text{number of parking spaces}}$$

Although the manual collection of parking data is still commonly used, it is now possible for all parking data to be collected electronically. Some of these electronic systems use wireless sensors to detect the arrival and departure of a vehicle at a parking space and the information sent to a central location through the internet. An example of this is the Spark Parking Inc. system. In addition to collecting data on parking, the Spark Parking System can be used to collect parking fees. The system provides for drivers to make calls soon after occupying a parking space from their mobile phones to record their credit cards and other personal information. The credit cards are then used for automatic payment of the parking fees. Figure 2 illustrates the general principles of the system.

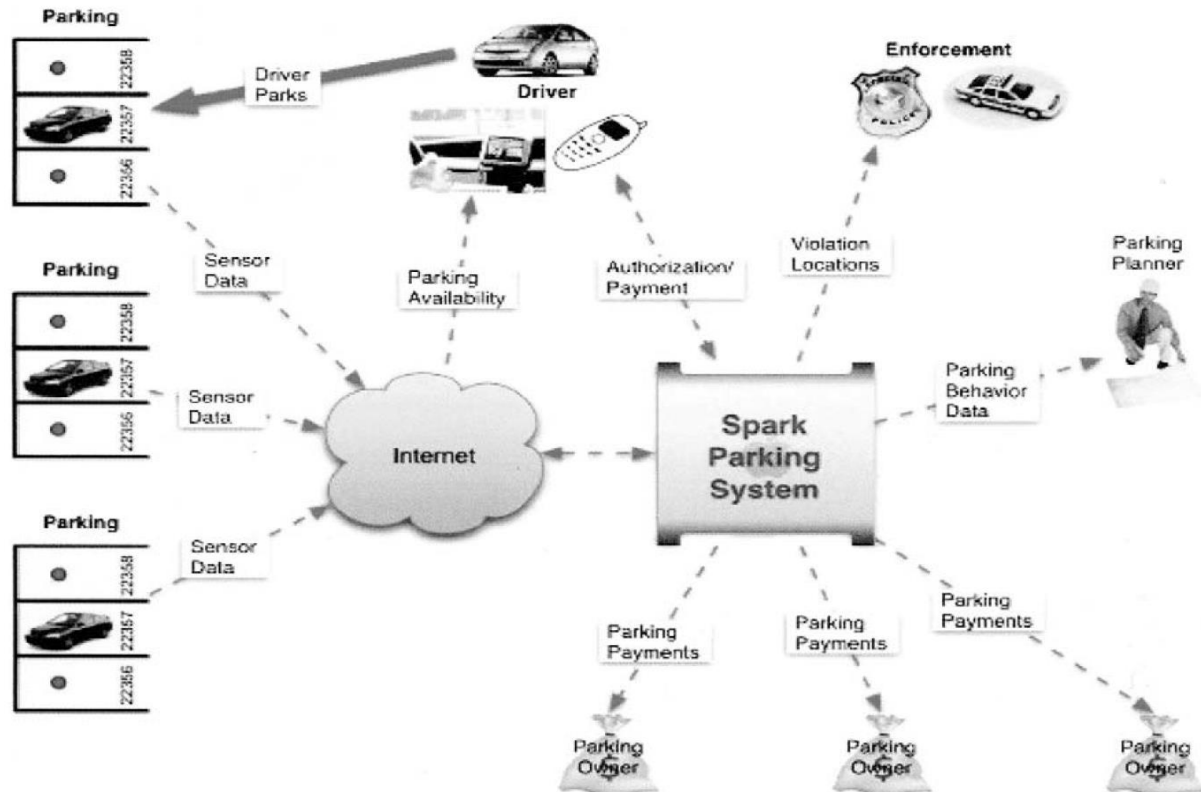

Figure 2 The Spark Service System

*Identification of Parking Generators:* This phase involves identifying parking generators (for example, shopping centers or transit terminals) and locating these on a map of the study area.

*Parking Demand:* Information on parking demand is obtained by interviewing drivers at the various parking facilities listed during the inventory. An effort should be made to interview all drivers using the parking facilities on a typical weekday between 8:00 a.m. and 10:00 p.m. The information sought should include (1) trip origin, (2) purpose of trip, and (3) driver’s destination after parking. The interviewer must also note the location of the parking facility, times of arrival and departure, and the vehicle type. Parking interviews also can be carried out using the postcard technique, in which stamped postcards bearing the appropriate questions and a return address are handed to drivers or placed under windshield wipers. When this technique is used, usually only about 30 to 50 percent of the cards distributed are returned. It is therefore necessary to record the time and the number of cards distributed

at each location, because this information is required to develop expansion factors, which are later used to expand the sample.

### Analysis of Parking Data

Analysis of parking data includes summarizing, coding, and interpreting the data so that the relevant information required for decision making can be obtained. The relevant information includes the following:

- Number and duration for vehicles legally parked
- Number and duration for vehicles illegally parked
- Space-hours of demand for parking
- Supply of parking facilities

The analysis required to obtain information on the first two items is straight forward; it usually involves simple arithmetical and statistical calculations. Data obtained from these items are then used to determine parking space-hours. The space-hours of demand for parking are obtained from the expression:

$$D = \sum_{i=1}^N (n_i t_i)$$

Where:

D = space vehicle-hours demand for a specific period of time

N = number of classes of parking duration ranges

t<sub>i</sub> = mid-parking duration of the i<sup>th</sup> class

n<sub>i</sub> = number of vehicles parked for the i<sup>th</sup> duration range

The space-hours of supply are obtained from the expression:

$$S = f \sum_{i=1}^N (t_i)$$

or  $S = f \times N \times t_i$

Where:

$S$  = practical number of space-hours of supply for a specific period of time

$N$  = number of parking spaces available

$t_i$  = total length of time in hours when the  $i^{\text{th}}$  space can be legally parked on during the specific period

$f$  = efficiency factor

The efficiency factor  $f$  is used to correct for time lost in each turnover. It is determined on the basis of the best performance a parking facility is expected to produce. Efficiency factors therefore should be determined for different types of parking facilities—for example, surface lots, curb parking, and garages. Efficiency factors for curb parking, during highest demand, vary from 78 percent to 96 percent; for surface lots and garages, from 75 percent to 92 percent. Average values of  $f$  are 90 percent for curb parking, 80 percent for garages, and 85 percent for surface lots.

### ***Example 1***

The owner of a parking garage located in a CBD has observed that 200 vehicles wish to park every day during the open hours of 8 a.m. to 6 p.m. An analysis of data collected at the garage indicates that 120 vehicles of those who park are commuters, with an average parking duration of 9 hr, and the remaining vehicles are shoppers, whose average parking duration is 2 hr. Determine the number of spaces required to meet the demand. Assume parking efficiency is 0.9.

### ***Solution***

Commuters now being served =  $120 \times 9 = 1080$  space-hr

Shoppers now being served =  $80 \times 2 = 160$  space-hr

Determine the number of parking spaces  $S$  required:  $S = 0.9 \times 10 \times N = 9N$

$9N = 1080 + 160 = 1240$  space-hr

$N = 137.77$  say 138 spaces are needed to accommodate the 200 vehicles.

### **Design of On-Street Parking Facilities**

On-street parking facilities may be designed with parking bays parallel or inclined to the curb. Figure 3 illustrates the angles of inclination commonly used for curb parking and the associated

dimensions for automobiles. The number of parking bays that can be fitted along a given length of curb increases as the angle of inclination increases from parallel (0 degrees) to perpendicular (90 degrees.) As the inclination angle increases, encroachment of the parking bays on the traveling pavement of the highway becomes more pronounced. Parking bays that are inclined at angles to the curb interfere with the movement of traffic, with the result that crash rates tend to be higher on sections of roads with angle parking than with parallel parking. When parking bays are to be provided for trucks and other types of vehicles, the dimensions should be based on characteristics of the design vehicle.

**Example 2**

Using the data of Example 1, (on-site parking facilities), determine the length of the curb needed to accommodate the vehicles on both sides of the road at 30°, 45°, 60°, and 90° angles.

**Solution**

At 90° angle:  $N = L/8.5$ , so  $L = 138 \times 8.5 = 1173$  feet, so  $L = 1173/2 = 586.50$  feet on each side.

At 60° angle:  $N = (L - 6.6)/9.8$ , so  $L = 138 \times 9.8 + 6.6 = 1359$  feet, so  $L = 1359/2 = 679.50$  feet on each side.

At 45° angle:  $N = (L - 6.7)/12$ , so  $L = 138 \times 12 + 6.7 = 1662.70$  feet, so  $L = 1662.70/2 = 831.35$  feet on each side.

At 30° angle:  $N = (L - 2.8)/17$ , so  $L = 138 \times 17 + 2.8 = 2348.80$  feet, so  $L = 2348.80/2 = 1174.40$  feet on each side.

At 0° angle:  $N = L/22$ , so  $L = 138 \times 22 = 3036$  feet, so  $L = 1173/2 = 1518$  feet on each side.

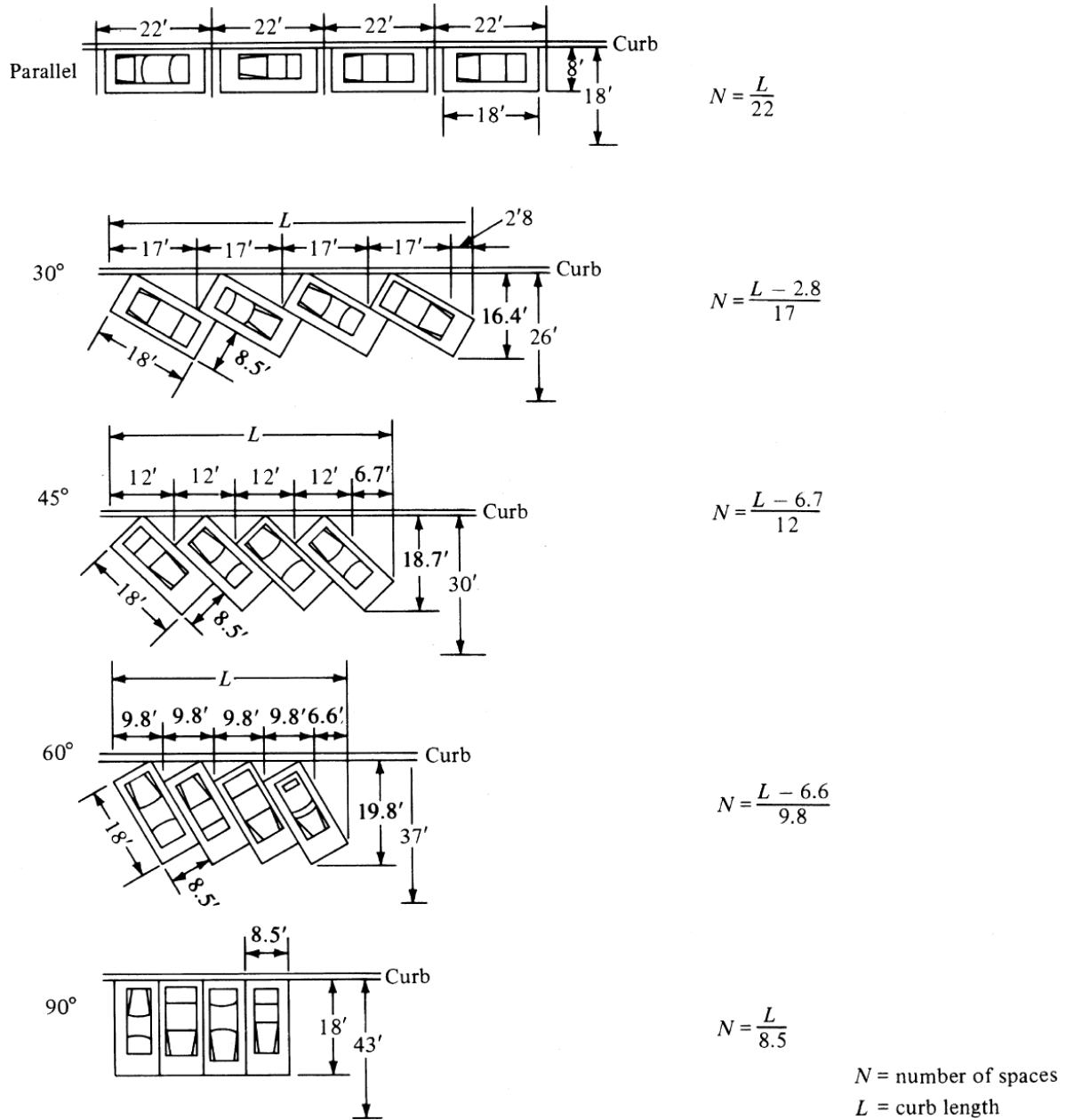

Figure 3 Street Space Used for Various Parking Configurations

### Design of Off-Street Parking Facilities

The primary aim in designing off-street parking facilities is to obtain as many spaces as possible within the area provided. Figures 4 and 5 show different layouts that can be used to design a surface parking lot. The most important consideration is the layout should be such that parking a vehicle involves only one distinct maneuver, without the necessity to reverse. The layouts shown indicate that parking spaces are efficiently used when the parking bays are inclined at 90 degrees to the direction of traffic flow. The use of the herringbone layout as illustrated in Figure 5 facilitates the traffic circulation because it provides for one-way flow of traffic on each aisle.

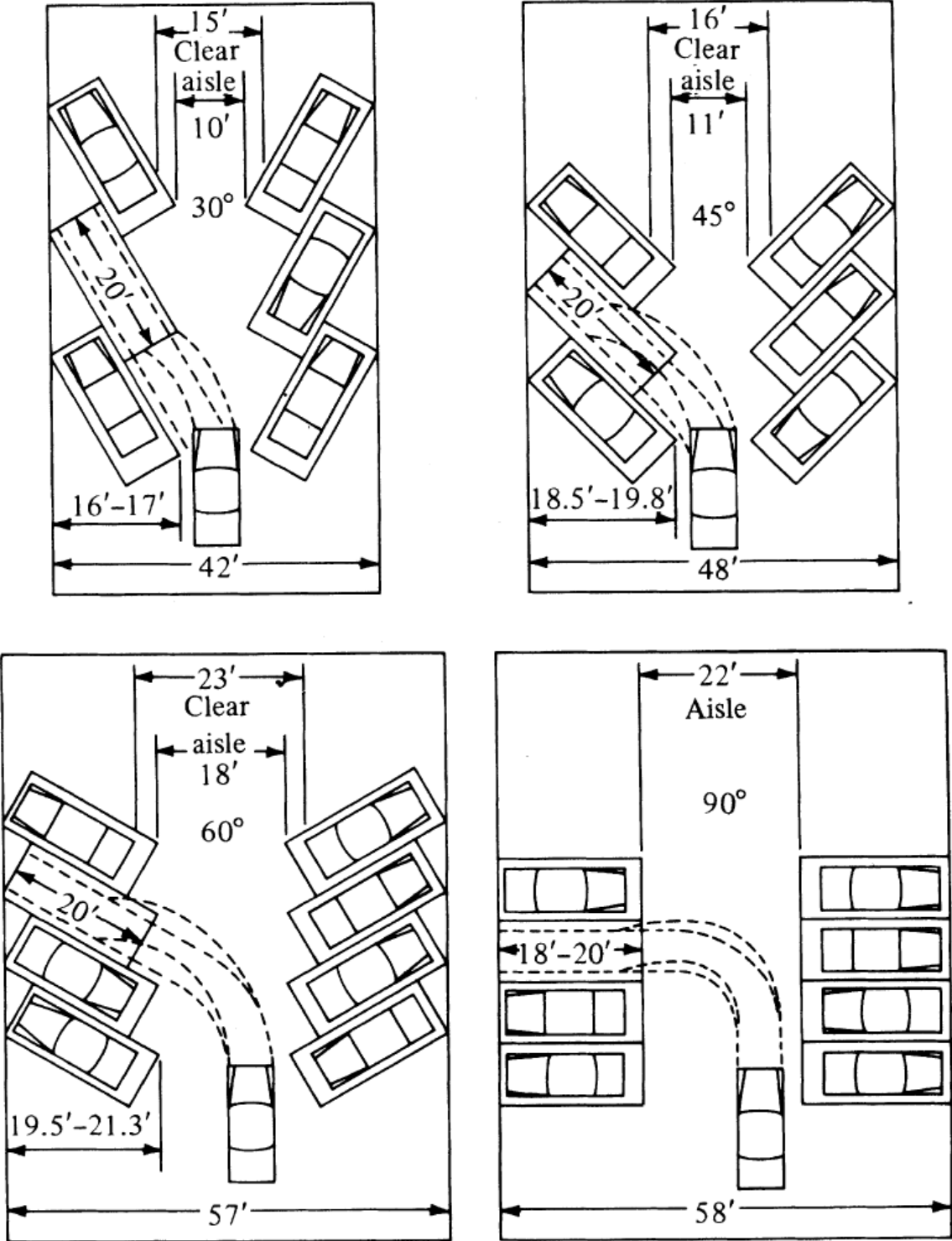

Figure 4 Parking Stall Layout



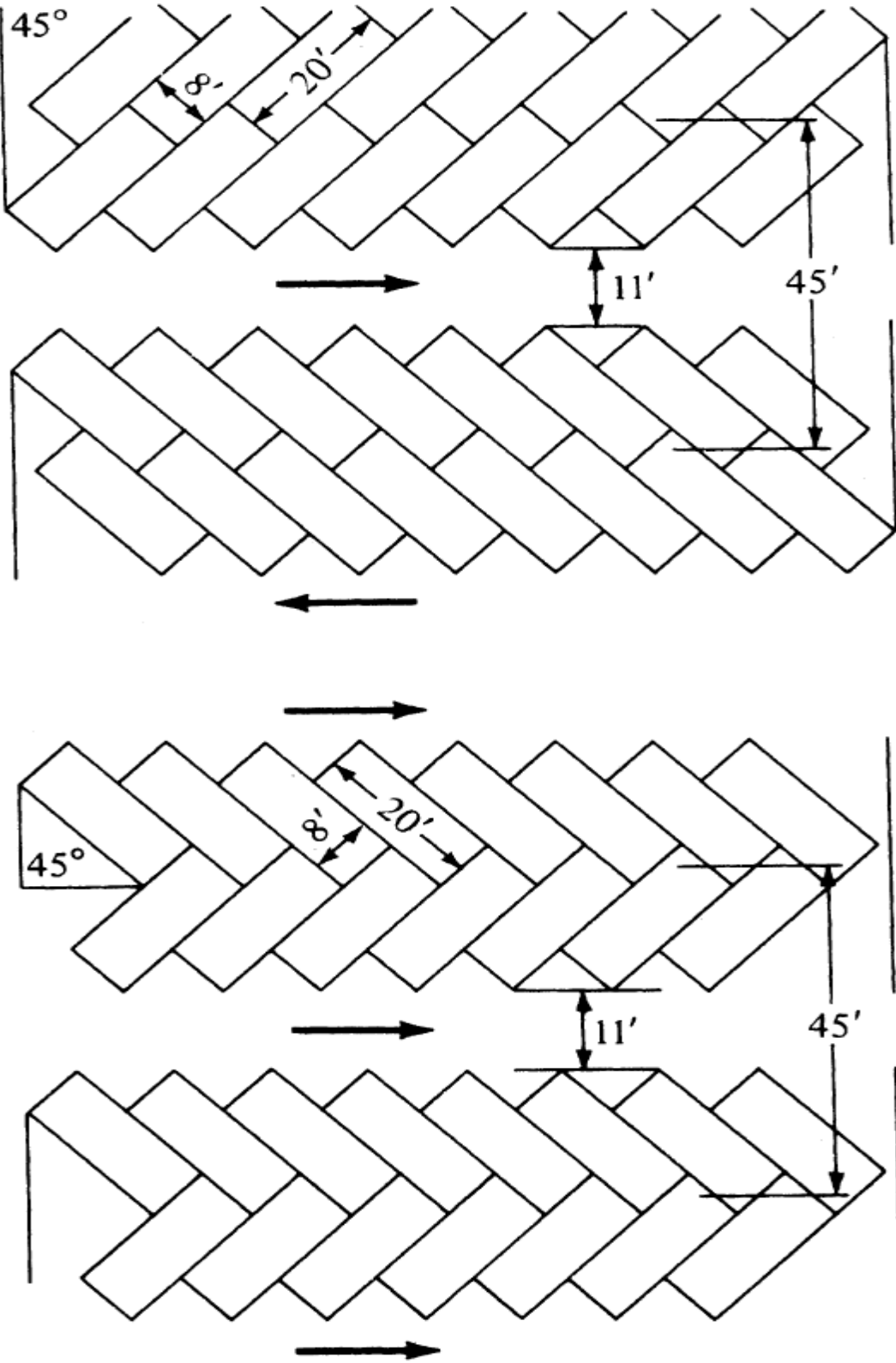

Figure 5 Herringbone Layout of Parking Stalls in an On-Surface Lot

### Design of Off-Street Parking Facilities—Garages

Parking garages consist of several platforms, supported by columns, which are placed in such a way as to facilitate an efficient arrangement of parking bays and aisles. Access ramps connect each level with the one above. The gradient of these ramps is usually not greater than 1:10 on straight ramps and 1:12 on the centerline of curved ramps. The radius of curved ramps measured to the end of the outer curve should not be less than 70 ft and the maximum superelevation should be 0.15 ft/ft. The lane width should not be less than 16 ft for curved ramps and 9 ft for straight ramps. Ramps can be one-way or two-way, with one-way ramps preferred. When two-way ramps are used, the lanes must be clearly marked and where possible physically divided at curves and turning points to avoid head-on collisions, as drivers may cut corners or swing wide at bends.

Platforms may be connected by elevators into which cars are driven or placed mechanically. Elevators then lift the car to the appropriate level for parking. The vehicle is then either removed by an attendant who parks it or is mechanically removed and then parked by that attendant. The size of the receiving area is an important factor in garage design and depends on whether the cars are owner-parked (self-parking) or attendant-parked. When cars are self-parked, very little or no reservoir space is required, since drivers need pause only for a short time to pick up a ticket from either a machine or an attendant. When cars are parked by attendants, the driver must stop and leave the vehicle. The attendant then enters and drives the vehicle to the parking bay. Thus, a reservoir space must be provided that will accommodate temporary storage for entering vehicles. The size of reservoir space depends on the ratio of the rate of storage of vehicles to their rate of arrival. The rate of storage must consider the time required to transfer the vehicle from its driver to the attendant. The number of temporary storage bays can be determined by applying queuing. Figure 6 is a chart that relates the size of reservoir space required for different ratios of storage rate to arrival rate, with overloading occurring only 1 percent of the time.

### General Considerations

There are four basic parking angles used for the rows of parking area stalls; these are illustrated below. Sixty degrees (60°) is the most common stall angle because it permits reasonable traffic lane widths and is easy to enter and back out of. In tight places, the forty-five degree (45°) stall is sometimes preferred, and the (30°) is even better. The small change in angle permits the use of narrower aisles. On the other hand, the ninety degree (90°) angle achieves the highest car capacity. This type of parking is more suited to all-day parking (such as employee parking) because it has the highest degree of difficulty for entering and leaving parking stalls. It is generally not preferred for “in and out” lots such as fast food restaurants and banks.

Individual parking stalls should be a minimum of nine feet by nineteen feet (9' x 19'). However, special sections with slightly smaller stalls may be designated for compact cars to better utilize the area. Two-way traffic lanes have a minimum width of twenty-four feet (24')

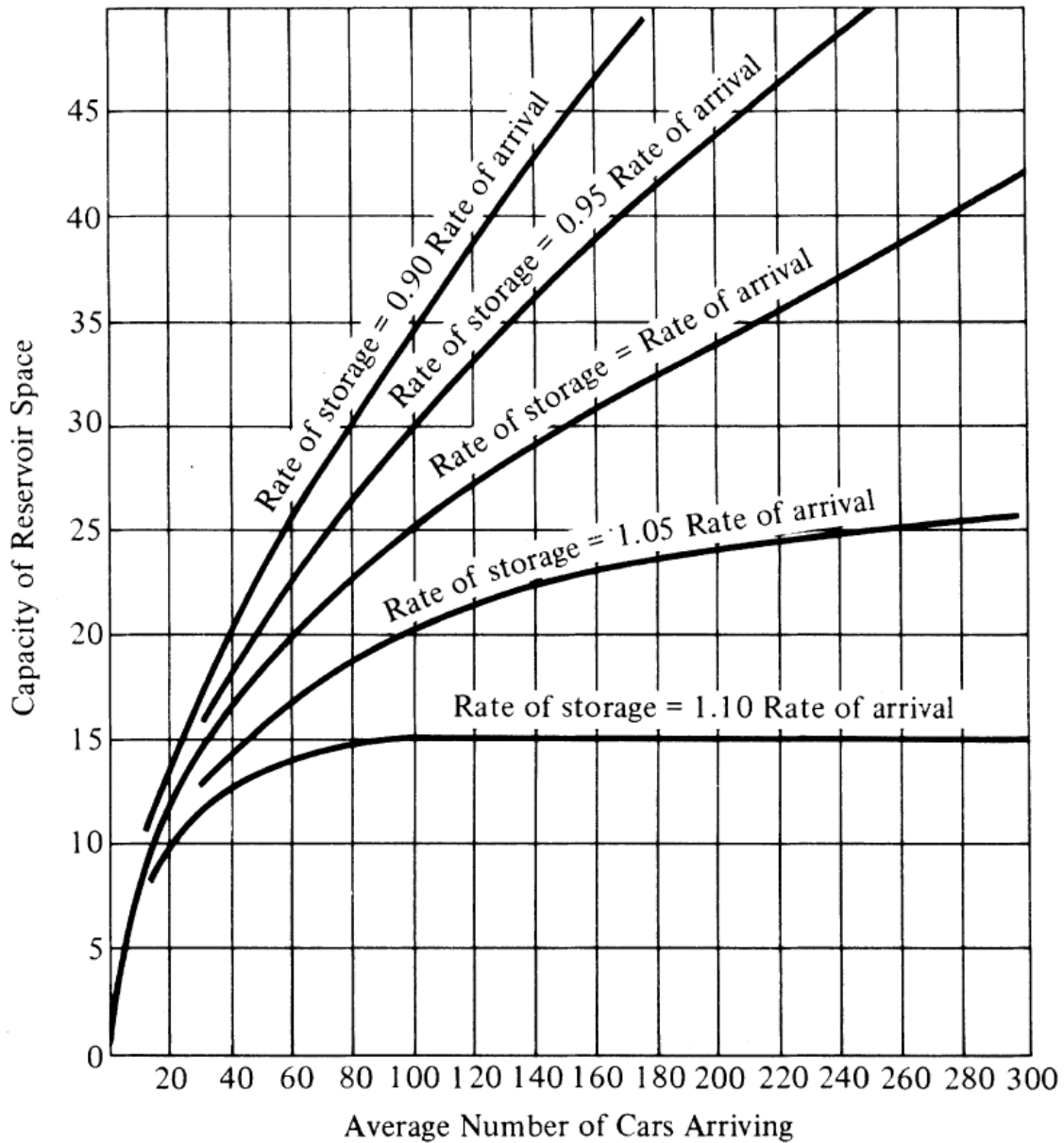

Figure 6 Reservoir Space Required If Facility Is Overloaded Less Than One Percent of Time

and perimeter circulation road lanes should be thirty feet (30'). When the parking lot access opening is limited to less than thirty feet (30') in width a separate entrance and exit should be used.

The minimum entrance radius is six feet six inches (6'- 6"). However, eleven feet six inches (11'- 6") is recommended.

Rear overhang minimums depend on the stall angle. 45° stalls require three feet three inches (3' - 3"), 60° stalls require three feet nine inches (3' - 9"); and 90° stalls require four feet (4').

## Section 3 — Parking Lot Drainage Design

### General Considerations

Adequate pavement drainage is of great importance to all pavement designs, especially for parking lanes. If the subgrade under the pavement becomes saturated, it will lose strength and stability and make the overlying pavement structure susceptible to break up under imposed loads. Both surface and subsurface drainage must be considered. All drainage must be carefully designed and should be installed in the construction process as early as is practicable. The pavement should also be constructed in a manner that will not permit water to collect at the pavement edge and provisions should be made to intercept all groundwater from springs, seepage planes, and streams. When used, curb and gutter sections should be set to true line and grade. Marshy areas will require special consideration and should be addressed during the planning stage. Refer to Figure 7.

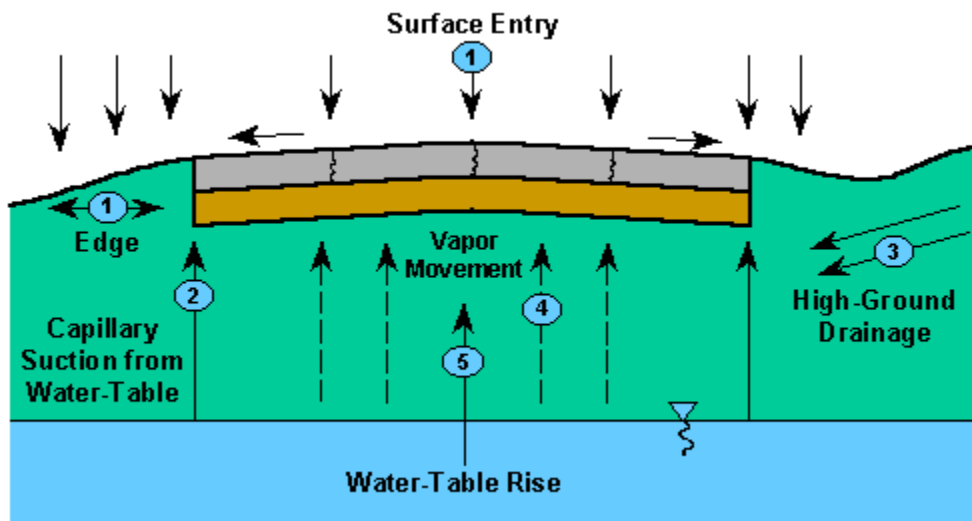

Figure 7 Drainage Considerations

Residential streets often are designed to follow natural drainage ways to permit rapid run-off from building lots. Both surface and subsurface drainage must be given careful attention to prevent accumulation of water. Where drainage is unusually difficult, it may be necessary to increase pavement thickness and install subgrade underdrains. (Underdrains are usually not required when full depth asphalt is used).

Drainage impacts pavement performance when the subgrade materials and pavement layer materials are saturated and lose strength. Water that falls on the pavement surface must be drained to curb and gutter systems or ditches. Water that penetrates the pavement from the surface; infiltrates from the sides of the road, or rises from under the pavement should not be allowed to compromise the overall strength.

Many subdivision streets are placed at too low an elevation resulting in the pavement carrying run off and acting as a drainage facility. This results in increased maintenance and shorter pavement life. Proper elevation and crown are essential to pavement surface drainage. To account for surface water drainage, it is important that the road is constructed with a crown or cross slope. Typically, a crown is placed in the center of the road and the pavement is sloped 2% in each direction. Occasionally, the pavement will be superelevated where one side of the road is higher than the other. In either case, the pavement must be sloped to keep water from ponding on the surface. Refer to Figures 8 and 9, for typical urban and rural roadways, respectively.

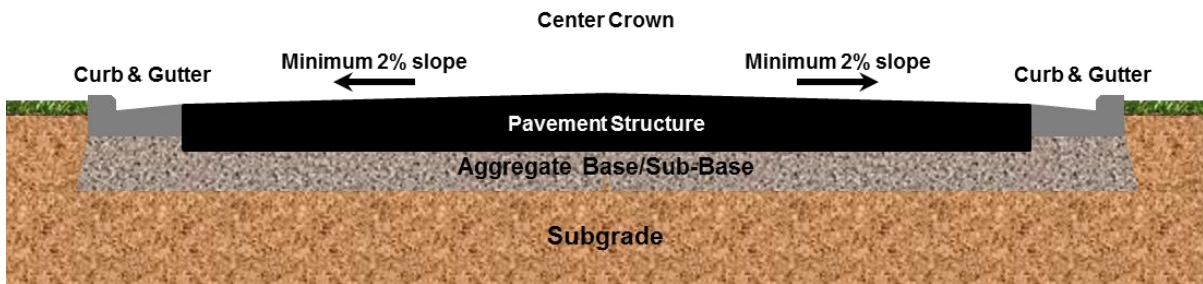

Figure 8 Cross-Section of Parking Lane (Urban Roadway)



Figure 9 Cross-Section of Parking Lane (Urban Roadway)

For subsurface water, the approach to address varies based on the project. In some situations, underdrains are placed to intercept water that may flow under a pavement. This water is then allowed to flow out into a ditch or is put in a stormwater system. In many cases where the subgrade becomes weaker due to water, the subgrade is stabilized with a binding agent, removed and replaced with a stronger material, covered with a stabilization fabric prior to placing the next pavement layer or the next pavement layers are made thicker.

### Drainage Provisions

Drainage problems are frequently a major cause of parking area pavement failures. This is especially the case with irrigation sprinkler systems located in parking lot islands and medians. It is critical to keep water away from the subgrade soil. If the subgrade becomes saturated, it

will lose strength and stability, making the overlying pavement structure susceptible to break up under imposed loads

The primary drainage function of parking lots is to convey minor storms quickly and efficiently to the storm sewer or open channel drainage with minimal impact on the vehicle/ pedestrian traffic and the surrounding environment. In addition, removing water quickly from paved surfaces will prevent water from reaching the subgrade, minimize cracks due to the weakened subgrade, and prolong the life of the pavement in a parking lot. Parking lot drainage requires consideration of surface drainage, gutter flow, inlet capacity, and inlet locations. The design of these elements is dependent on storm frequency and rainfall intensity.

When rain falls on a sloped pavement surface, part of it infiltrates into the ground, part of it evaporates into the air, and the remainder runs off from the high point to the low point as a result of gravity. The runoff water forms sheet flow – a thin film of water that increases in thickness as it flows to the edge of the pavement. Factors which influence the depth of water on the pavement are the length of flow path, surface texture, surface slope, and rainfall intensity.

Surface drainage for a parking lot consists of slopes, gutters, and inlets. Desirable gutter grades should not be less than 0.5 percent (0.005 ft/ft) for curbed pavements with an absolute minimum of 0.3 percent.

Water is probably the greatest cause of distress in a paved structure. The efficient removal of a storm runoff from paved surfaces has a positive effect on parking lot maintenance and repair. A minimum slope of 0.4 percent (0.004 ft/ft) shall be used for the paved surfaces. Parking lots with grades flatter than 0.4 percent are subject to ponding and are candidates for installing underground storm sewers. To achieve adequate drainage, a slope between 2% and 5% is recommended for paved surfaces in a parking lot.

### **Curb and Gutter**

Many parking facilities have some form of curbing around the perimeter for both functional and aesthetic reasons. The three basic types of systems are: concrete curb and gutter, asphalt curbs, and concrete curbs with sidewalks.

One of the most common errors in pavement design, however, is not specifying the appropriate grades to ensure that water does not collect on the pavement. Many parking facilities with curb and gutter have the elevation of the pavement below that of the curb and gutter. As water is the biggest enemy of any pavement, these “dry curbs” will result in poor pavement performance and shorter pavement life. Note: To function correctly curb and gutter should always be downslope from the pavement surface so the surface runoff from the pavement will drain into the gutter.

## **Section 4 — Parking Lot Pavement Design**

### **Asphalt Surface Course**

Material for the surface course should be an asphalt concrete mix placed in one or more lifts to the true lines and grade as shown on the plans or set by the owner. The asphalt concrete



should conform to the Department of Transportation specifications. The asphalt surface should not vary from established grade by more than one-eighth inch (1/8") in ten feet (10') when measured in any direction. Any irregularities in the surface of the pavement course should be corrected directly behind the paver. Rolling and compaction should start as soon as the asphalt concrete can be compacted without displacement and continued until thoroughly compacted and all roller marks disappear.

### **Tack Coat**

Prior to placement of successive pavement layers, the previous course should be cleaned and, if needed, a tack coat of emulsified asphalt applied. The tack coat may be eliminated if the previous course is freshly placed and thoroughly clean.

### **Pavement Surface Sealants**

When there is a danger of petroleum spillage or leakage, such as gas station parking areas, the new asphalt pavement should be sealed with a good quality commercial pavement sealant to prevent the asphalt from being dissolved. Most new asphalt parking facilities, however, do not require a sealer on the pavement surface. The asphalt contractor should be consulted concerning the use of any sealant.

If a sealant is warranted, the new asphalt pavement should be allowed a minimum of thirty days (30) before any sealant is applied to the surface. This permits the petroleum distillates contained in the pavement to evaporate. Sealing the new asphalt too quickly can result in the sealer delaminating from the new asphalt surface.

### **Base Construction (Asphalt)**

Prior to placement of the asphalt concrete base course, the subgrade should be graded to the established requirements, adequately compacted, and all deficiencies corrected. The asphalt concrete base course should be placed directly on the prepared subgrade in one or more lifts, spread, and compacted to the pavement thickness indicated on the plans or established by the owner. (Compaction of asphalt mixtures is one of the most important construction operations contributing to the proper performance of the completed pavement, regardless of the thickness of the course being placed. This is why it is so important to have a properly prepared subgrade against which to compact the overlying pavement).

### **Base Construction (Aggregate)**

The subgrade must be graded to the required contours and grade in a manner as will ensure a hard, uniform, well-compacted surface. All subgrade deficiency corrections and drainage provisions should be made prior to constructing the aggregate base. The crushed aggregate base course should consist of one or more layers placed directly on the prepared subgrade, spread, and compacted to the uniform thickness and density as required on the plans or established by the owner. Absolute minimum crushed aggregate thickness is six inches (6").

All crushed aggregate material should be of the Department of Transportation approved type and suitable for this type of application.

### **Subgrade Preparation**

Because the subgrade must serve both as a working platform to support construction equipment and as the foundation for the pavement structure, it is most important for the architect or engineer to see that it is properly compacted and graded. A visual examination will usually reveal the adequacy of the elevation. However, laboratory tests to evaluate the load-supporting characteristics of the subgrade soil are desirable. If these tests are not available, designs may be chosen based on careful field evaluations and previous projects and experience in the area.

All underground utilities should be protected or relocated prior to grading. All topsoil should be removed and low-quality soil must be improved by adding asphalt or other suitable admixtures such as lime or granular materials.

The areas to be paved should have all rock, debris, and vegetation matter removed and be treated with a soil sterilizing agent to inhibit future flora growth. Grading and compaction of the area should be completed in such a manner as to prevent yielding areas or pumping of the soil. The subgrade should be compacted to a uniform density of 95% of the maximum theoretical density.

Should a weak spot be discovered, the material should be removed and replaced with either six inches (6") compacted crushed stone or three inches (3") compacted asphalt concrete. In case of extremely poor subgrade, it may be necessary to remove the upper portion of the subgrade and replace it with a selected material. When finished, the graded subgrade should not deviate from the required grade and cross section by more than one-half inch (1/2") in ten feet (10').

### **Truck Lanes for Loading, Dumpsters, etc.**

The pavement for truck lanes used for loading, deliveries, etc., must be increased in thickness to prevent pavement failure due to the weight associated with heavy trucks. These areas should be constructed with asphalt pavement thicknesses that will support this heavier, pavement loading, typically a minimum of 3" of base asphalt under the surface course and over a 6"- 8" aggregate subbase.

For areas where trash truck service waste containers and dumpsters special pads and approaches are required to handle their heavy and special dynamic loading. Often full-depth concrete pads are constructed but this is a costly alternative to a full-depth asphalt pad. However, failure to provide one of these two types of truck lanes/dumpster pads can result in severe pavement failure. A common mistake made at many facilities is constructing pads that are only large enough for the dumpster to sit on. The severe loading and potential to damage the pavement structure comes from the trash trucks, not the dumpster. Therefore, the pads need to be large enough to accommodate the trash truck when servicing the dumpster.



### Pavement Structure

The pavement structure and materials used will change as a function of subgrade strength and construction approach. Some projects will use full-depth asphalt (i.e., asphalt placed directly on compacted subgrade) and some will use an aggregate base placed on compacted subgrade. The aggregate base will be covered with one or more layers of asphalt. The figures below (10, 11, 12, 13) show the minimum pavement designs. Each layer is the compacted thickness. At no time should less than 6 inches of an aggregate subbase layer be used.

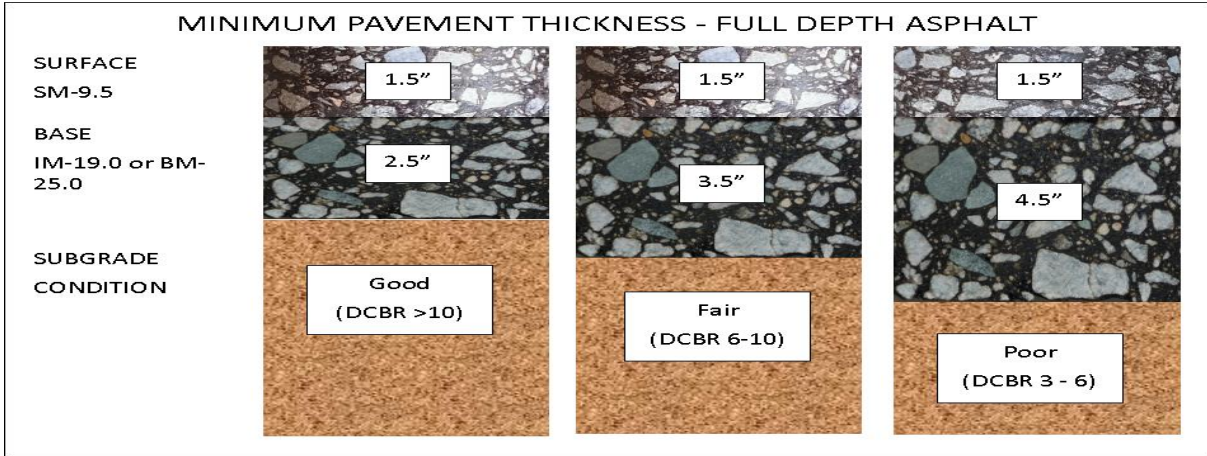

Figure 10 Full-Depth Asphalt Pavement (Parking Stall Areas)

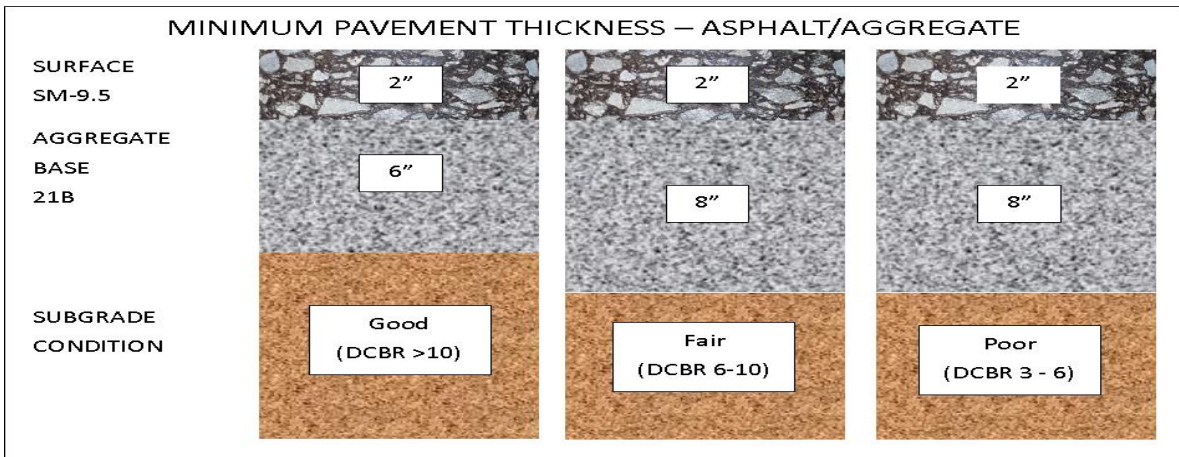

Figure 11 Asphalt with Aggregate Sub-Base Pavement (Parking Stall Areas)

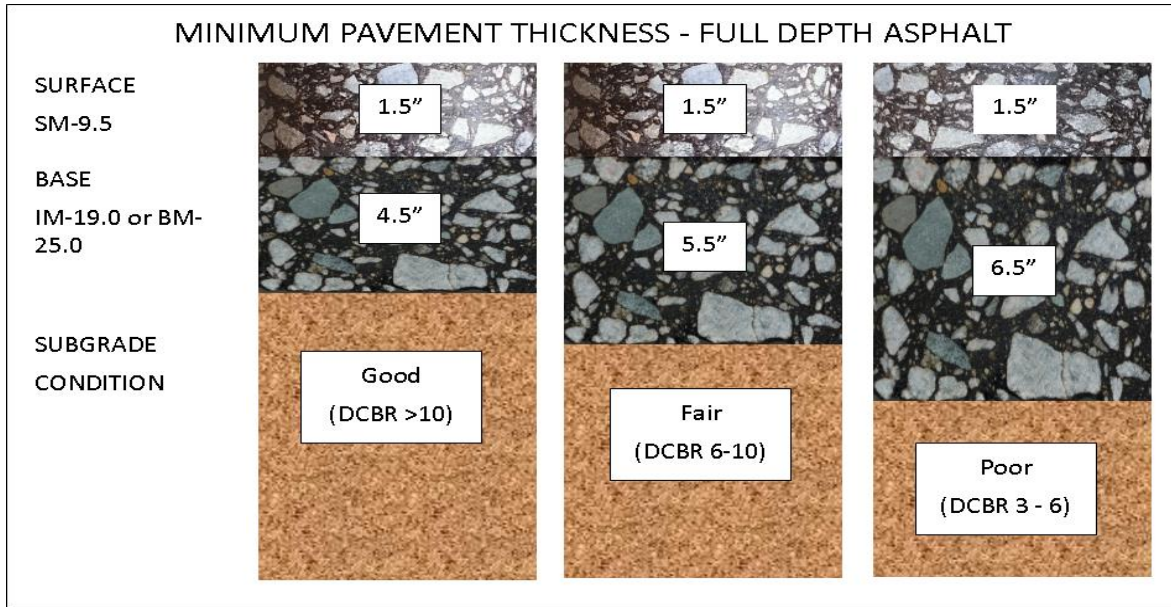

Figure 12 Full-Depth Asphalt Pavement (Truck/Bus Drive Lanes)

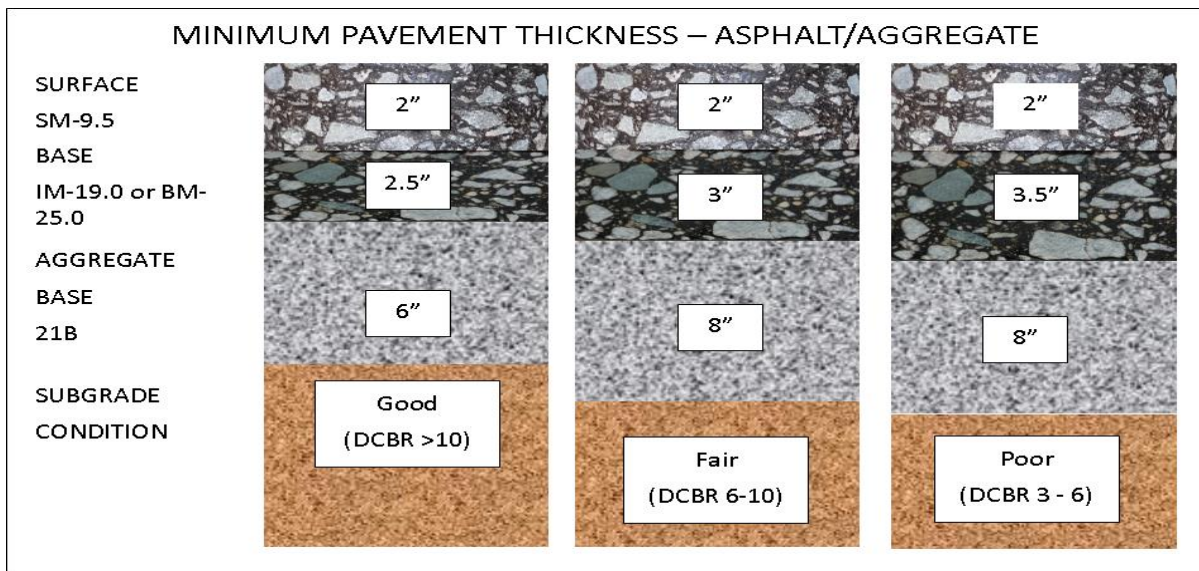

Figure 13 Asphalt with Aggregate Sub-Base Pavement (Truck/Bus Drive Lanes)

Notes:

- SM-9.5 is a common mix for most asphalt producers. However, some producers may have an SM-4.75, SM-9.0 or SM-12.5 available as well.
- SM-2A and S-5 are equivalent to SM-9.5.
- Design CBR (DCBR) is defined as 2/3 of the soaked CBR value.

## Future Maintenance Considerations

In time, pavement failures may occur due to settlement or weakening of the soil or aggregate base layers. These will result in localized failures or potholes. To repair these failures, the area impacted should be cut out and the pavement material removed to the subgrade. The subgrade material may need to be removed and replaced or simply re-compacted. Finally, the removed pavement material should be replaced with new asphalt concrete or a permanent asphalt patching material.

As asphalt ages, shrinkage cracks will develop. Individual transverse and longitudinal cracks should be sealed with an asphalt-based material to reduce the amount of water infiltrating the underlying pavement layers. If the cracking is extensive, then the pavement can be overlaid with a new AC surface or milled and replaced with a new AC surface. Overlaying can be performed on parking lots without curb and gutter. For lots with curb and gutter, milling may be needed to maintain surface drainage. While edge milling can be performed, typically 4 to 6 feet in width at the edge of the pavement, full pavement milling is recommended in order to keep proper cross-slope.

## Section 5 — Miscellaneous Design Considerations

### Painting (Marking) and Striping

Paint striping and marking are important parts of a good parking area. All pavement striping should be four inches (4") in width with double lines to mark the individual parking stalls. The parking area should be clearly marked with symbols, words, and numbers to direct traffic flow. White paint should be used to designate all lines and markings except for dangerous areas, which should be painted yellow.

#### Layout

The project design drawings must include a detailed and accurately scaled parking lot layout clearly showing the location of parking spaces and aisles.

#### Painting (Marking)

The construction documents should include the parking spaces to be marked on the project design drawings, and should conform to the following criteria:

- Each required parking space should be identified by surface markings and should be maintained in a manner so as to be readily visible and accessible at all times. Such markings should be arranged to provide for orderly and safe loading, unloading, parking and storage of vehicles.
- One-way and two-way access into parking facilities should be identified by directional arrows. Any two-way access located at any angle other than 90° to a street should be



marked with a traffic separation stripe the length of the access. This requirement does not apply to aisles.

- Markings that are required to be maintained in a highly visible condition include striping, directional arrows, lettering on signs, lettering in handicapped-designated areas, and field color. (Refer to Figure 14).



Figure 14 Accessible Space Marking

- Each loading space should be striped or permanently designated by other suitable methods and permanently posted with a sign restricting its use to loading.
- Parking spaces should be permanently marked with striping in accordance with all federal, state and local standards. As a minimum, lines should be located along the sides and, unless curbing is present, at the head of parking stalls. Lines should be four (4) inches wide and should extend the full length of the space.
- “YIELD” markings should be painted in yellow letters a minimum of 36” high at the end of each parking row as it intersects either a drive lane or another parking row that has priority flow for traffic.

### Striping

Striping should be one consistent color, semi-permanent, reflective traffic paint with reflective glass beads to enhance visibility. If oil based paint is utilized, then a single coat is sufficient. If water base paint is utilized, then two coats are required with the second coat being applied at least two months after the first. Stop signs and crosswalks should be painted with rubber (plastic) paint with reflective glass beads to enhance visibility. Parking spaces will be striped

white except at the end of each row of parking or at handicapped accessible aisles. These lines will be painted yellow. All cross walks, no parking areas and access walks will be striped in yellow. All lines must be 4” wide.

**Re-Striping**

When an existing parking lot is re-striped, the re-striping must provide accessible parking spaces as required by the Americans with Disabilities Act (ADA) Standards for Accessible Design.

**Bumpers and Stops**

There are a wide variety of bumpers, stops, and barricades commercially available for parking areas. Asphalt concrete curbing is widely used, as are Portland cement concrete and stone. Steel poles three inches (3”) in diameter are usually used to protect pedestrian walkways, fire plugs, structural supports, etc. The application and use of these should be evaluated and included in the plans or contract.

**Purpose**

All parking areas and spaces should be provided with bumper barriers, wheel stops, or wheel stop curbing designed to prevent parked vehicles from extending beyond the property lines, damaging adjacent landscaping, walls or buildings, or overhanging sidewalk areas. Each handicapped accessible parking space without a curb stop should be furnished with a parking barrier. Barriers should not block the access aisles between handicapped accessible spaces.

**Approved Barriers (Wheel Stops)**

Prefabricated concrete parking barriers, where used, should be a minimum of 6” wide, 6” high, and 6 feet long (See Figure 15). Prefab barriers must be firmly and permanently anchored a minimum of 12” below the pavement with galvanized anchor pins (See Figure 16).

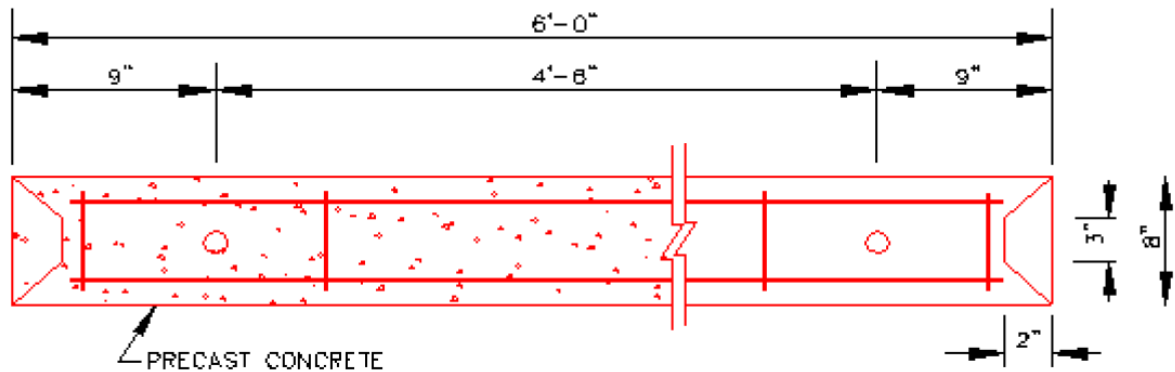

Figure 15 Precast Concrete Parking Barrier

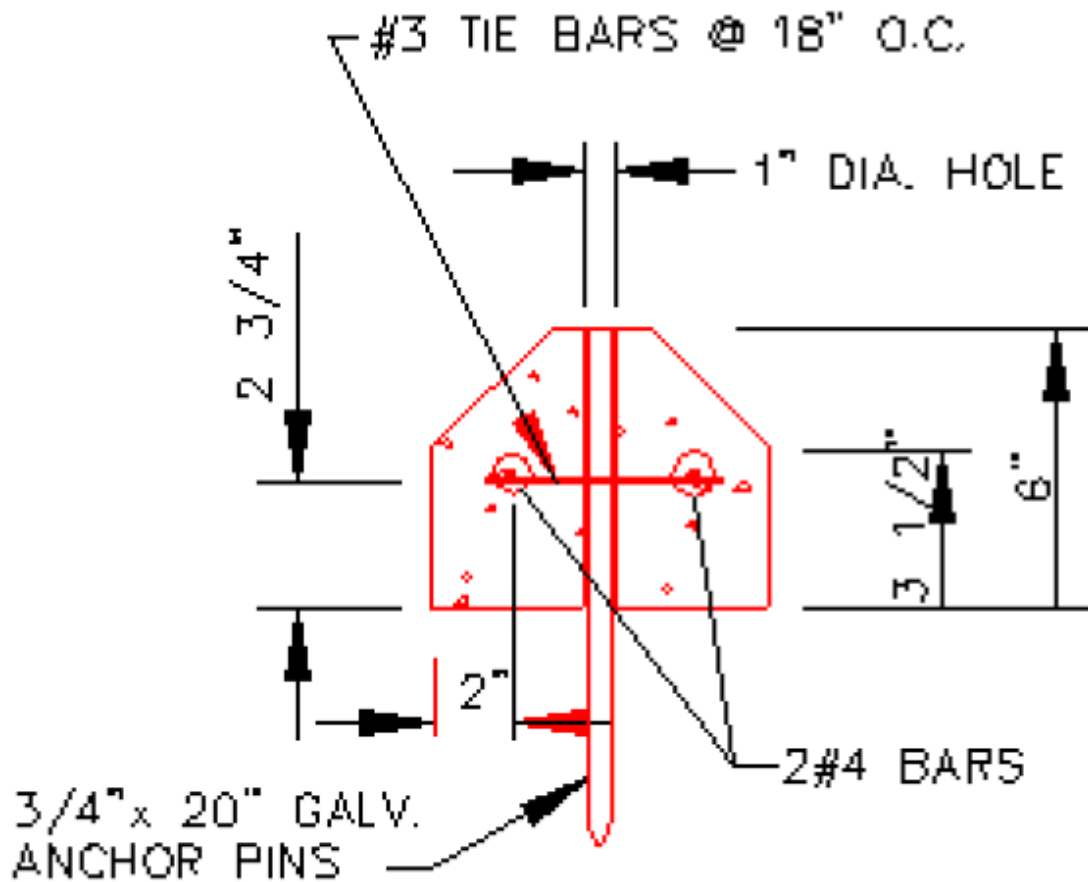

Figure 16 Parking Barrier Anchors

#### Location

Barriers should be located to contain the parking within the approved parking lot. When a concrete curb is used as a barrier for perpendicular or angle parking, it should be offset at least two (2) feet from the edge of the parking lot to allow for the front overhang of the vehicle.

#### Painting/Marking

All parking barriers (wheel stops) should be painted white except for the following:

- Yellow – No Parking / Tow Away Zones
- Red – Emergency Vehicle / Fire Zones
- Blue – Handicapped Parking
- Black Letters – Denote Reserved Spaces (usually with a space number)

## Benefits

Properly placed barriers protect structures and landscaping from vehicle damage. Bumpers encourage drivers to pull all the way into a parking space. This ensures adequate clearance behind the vehicle for other traffic. Bumpers along a centerline of a double row of parking can prevent drivers from taking unsafe short cuts through a parking lot.

## Green Considerations

### Porous Asphalt

*Porous Asphalt:* Porous asphalt pavements offer developers and planners a new tool in their toolbox for managing storm water runoff. These pavements, used mostly for parking lots, allow water to drain through the pavement surface into a stone recharge bed and infiltrate into the soils below the pavement. Such pavements have been proving their worth since the mid-1970s, and recent changes in storm water regulations have prompted many consulting engineers and public works officials to work with them.

*What Porous Asphalt Can Do:* Porous asphalt pavements are of great interest to site planners and public-works departments. With the proper design and installation, porous asphalt can provide cost-effective, attractive pavements with a life span of more than twenty years and at the same time provide storm-water management systems that promote infiltration, improve water quality, and many times eliminate the need for a detention basin. The performance of porous asphalt pavements is similar to that of other asphalt pavements. Additionally, like other asphalt pavements, they can be designed for many situations.

The technology is simple. The secret to success is to provide the water with a place to go, usually in the form of an underlying, open-graded stone bed. As the water drains through the porous asphalt and into the stone bed, it slowly infiltrates into the soil. The stone bed size and depth must be designed so that the water level never rises into the asphalt. This stone bed, often 18 to 36 inches in depth, provides a tremendous sub base for the asphalt paving.

Special features such as the underlying stone bed are more expensive than conventional construction, but these costs are more than offset by the elimination of many elements of standard storm-water management systems. On those jobs where unit costs have been compared, a porous asphalt pavement is generally the less-expensive option. The cost advantage is even more dramatic when the value of land that might have been used for a detention basin or other storm-water management features is considered.

Even after twenty years, porous pavements can show little if any cracking or pothole problems. The surface wears well. Porous asphalt retains its ability to handle rain water for many years. In a study of a porous pavement system constructed at the Pennsylvania State Visitor center, researchers found that the system had maintained a consistent infiltration rate. During a 25-year precipitation event, there was no surface discharge from the stone beds.

*Appearance of These Pavements:* While slightly coarser than standard asphalt, porous asphalt pavements are attractive and acceptable. Most people parking on a porous asphalt parking lot will not notice (or believe) that it is porous. The surface of a porous asphalt pavement is smooth enough to meet requirements of the Americans with Disabilities Act (ADA).

An added advantage to porous asphalt is that it does not necessitate proprietary ingredients. It does not require the contractor to have special paving equipment or skills. With the proper information, most asphalt plants can easily prepare the mix and general paving contractors can install it. The available data indicate a very high removal rate for total suspended solids, metals, and oil and grease.

*Environmental Benefits:* Because of the open structure of the pavement, porous asphalt offers a “cooler” pavement choice. By replenishing water tables and aquifers rather than forcing rainfall into storm sewers, porous asphalt also helps to reduce demands on storm sewer systems. In areas where storm-water impact fees are imposed by local governments, such fees may be reduced by using porous asphalt.

#### Planting Strategies

Vegetation is an effective and attractive way to reduce runoff, and smaller parking lots free up more space for landscaping. Leaves, stems and branches intercept rainwater, which then evaporates. A significant amount of storm water can evaporate from beds of tall grasses, wildflowers, shrubs, and trees. Furthermore, deep-rooted prairie plants create channels that help encourage infiltration. They also hold up to a half-inch of storm water on their leaves and in the thatch they create. Shallow-rooted turf grass is not nearly so effective, thus, deep-rooted perennial plantings are substituted for sod wherever possible.

Even if extensive perennial planting is not possible, trees are included to canopy paved areas. In addition to intercepting rainwater, the summer shade they provide helps to reduce the urban heat island effect and make parking lots more pleasant places to be.

*Infiltration:* Planted areas can also be designed specifically to accept runoff of parking areas, providing temporary storage and on- site infiltration.

#### Advantages:

- Less paving means lower development and maintenance costs.
- Grasses, wildflowers, shrubs, and trees hold water that is then evaporated, reducing runoff.
- Channels created by deep roots encourage infiltration.
- Shade from trees helps reduce the urban heat island effect and make the area more comfortable for people.



- Planting native vegetation creates wildlife habitat.
- A variety of vegetation creates a more interesting and aesthetically pleasing environment.
- Trees shade impermeable surfaces, keeping storm water cool and reducing urban heat island effect.

Limitations:

- Municipalities may have firm parking requirement that do not encourage innovation.
- Space allocated for parking lot in a given development may not be sufficient to include significant planted areas.
- Soil type may limit infiltration and/or planting success.
- Use the most space-efficient stall configuration for the site.
- In larger commercial parking lots, design 30 percent of the spaces for compact cars.
- Use pervious surfacing in summer spillover parking areas.
- If soils are suitable, drain parking lot runoff into infiltration islands using curb cuts or flat curbs.
- If soils are unsuitable, excavate to a depth of 3 feet and fill with a planting soil mix.
- Plant native or vigorous nonnative perennials rather than turf grass over as much of non-paved surfaces as possible.

The aim is to have canopy trees at maturity cover at least 50 percent of the paved surfaces. Since the tree height and spread will generally be smaller than normal in parking lot growing conditions, compensation is to be provided by planting more trees closer together.

The irrigation systems are usually necessary for parking lot island plantings, unless sufficient runoff is directed into them.

*Construction:* To avoid compaction, do not drive on planting areas during construction. After construction, loosen soils in planting areas to a depth of 24 inches, to a maximum compaction of 85 percent standard proctor density, till the upper 10 inches of soil.

*Maintenance:*

- Planted areas must be weeded monthly during the first two to three years. After that, weeding once or twice a growing season may suffice.
- Regular watering will be necessary during dry spells. Limit irrigation to a maximum of two inches per week.
- During winter plowing, push street snow away from swales whenever possible in order to avoid accumulation of road salt and sand.

## Lighting

### Purpose

Parking lot lighting is vital for traffic safety, for protection against assault, theft and vandalism, for convenience, and for comfort to the user. Lighting on parking lots can be designed to provide the minimum lighting necessary to ensure adequate vision and comfort while being arranged so as not to cause visual interference on public thoroughfares or encroach on the visual privacy of adjacent building occupants.

### Criteria

Lighting systems are to be designed to conform with Illuminating Engineering Society of North America (IESNA) requirements, to the International Dark-Sky Association (IDA) recommendations, and to the following criteria:

*General:* All parking lot lighting will utilize a standard luminaire and pole height.

*Illumination Level within the Parking Lots:* Illumination levels at any point across the parking lot must not be greater than 6.0 foot-candles in the horizontal plane, and must not exceed 0.5 vertical foot-candles. All points across the interior of the parking lot should have an illumination level greater than 3.0 foot-candles. Illumination in low traffic areas should not fall below the 2.5 foot- candles level.

*Illumination Level Beyond the Parking Lot Perimeter:* Illumination attributable to a parking lot lighting system should not exceed 0.50 horizontal foot-candles beyond the perimeter of the parking lot.

*Illumination Level at High Traffic Areas:* Illumination levels at entrances, exits, loading zones and collector lanes of parking areas should be greater than twice the illumination of the adjacent parking area or the adjoining street, whichever is greater.

*Uniformity Ratio:* The illumination uniformity ratio should not exceed 3:1, average to minimum, or 4:1 maximum to minimum. The use of unnecessarily high wattage lights can actually lead to a less secure environment by creating dark pockets just outside the range of the lights.

*Glare Control:* Lighting should be designed to protect against glare onto public rights-of way that could impair the vision of motorists and adversely impact adjoining properties. Lighting adjacent to buildings and/or residential districts must be arranged so that the luminaires have a sharp cutoff at no greater than 78° vertical angle above nadir. Not more than five (5) percent of the total lamp lumens can project above 78° vertical.

*Spillover:* In the ideal case, all exterior light would be shielded from the adjacent properties by the existing vegetation, thick evergreen vegetated buffers, berms, walls or fences, and/or the use of directional lighting, lighting shields, special fixtures, timing devices, appropriate light densities, luminaires, and mountings at established heights. A design objective for parking lots is for outdoor lighting to be designed and located such that the maximum illumination measured in foot-candles at the property line should not exceed 0.5 onto adjacent residential sites and 1.0 onto adjacent commercial sites and public rights-of-way.

*Orientation:* The intent of parking lot lighting is to minimize or eliminate light directed upward. Light emitted at angles of 80° higher (where straight down is 0°) fails to produce useful illumination on horizontal surfaces in open areas. At these high angles light produces significant glare, light pollution, and energy waste. Light above 90° is totally wasted and produces undesirable sky glow.

*Placement:* The placement of the light poles within raised curb planter areas is encouraged, but conflicts with the parking lot trees, which can obscure the lighting, should be avoided. The distance separating lights will be determined by the geometry of the parking lot and the requirement to satisfy the illumination levels.

### Luminaires

*Mounting Height:* The mounting height is measured from the finished grade or surface and includes the total height of the luminaire, pole, and any base or other supporting structure required to mount the light. Parking lot luminaires should be designed, located and mounted at heights no greater than 33-feet above grade for cutoff lights. (Refer to Figure 17).

*Pole Bases:* Raised light pole bases should be attractively designed. A typical standard is a 2 ft. diameter, cylindrical concrete base set 8.0 ft. below and 2.5 ft. above grade. The top of the base must be finished in a slight convex shape to prevent water pooling at the base of the light pole.

*Interior Coating:* Interior pole shaft surfaces should be mechanically cleaned and coated at the base end for a length of approximately 2.0' with a zinc rich epoxy powder. The coating should

be electrostatically applied and cured in a gas fired convection oven by heating the steel substrate to a minimum of 350° F and a maximum of 400° F.

*Exterior Coating:* All exterior surfaces should be coated with either Urethane or Triglycidyl Isocyanurate (TGIC) Polyester Powder to a minimum dry film thickness of 2.0 mils for Urethane Powder and 3.0 mils for TGIC Powder. The coating should be electrostatically applied and cured in a gas fired convection oven by heating the steel substrate to a minimum of 350° F and a maximum of 400° F.

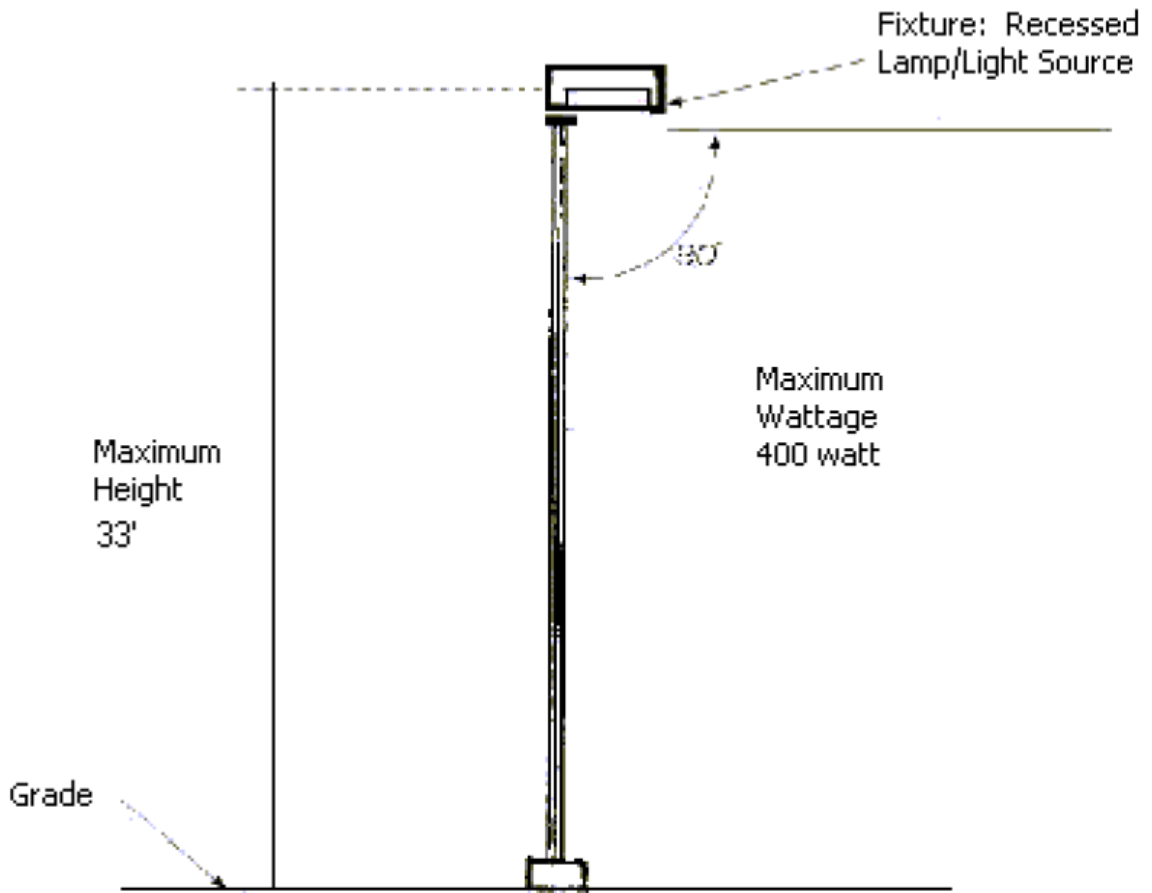

Figure 17 Cutoff Light feature

## Landscaping of Parking Areas

### General Guideline

Vehicular parking areas should be both functionally and aesthetically pleasing. The overall goals of implementing these requirements are to enhance, beautify, and improve the environmental and climatic impact of surface parking lots and to minimize the vast, barren character of existing and future parking areas while providing efficient parking, vehicular circulation and safe pedestrian access. Large canopy trees should dominate the parking areas for shade and shrubs along the perimeter should be provided for screening. Additional information is included in the discussion of environmental issues.

### Numerical Requirements

The parking lot design should include, at a minimum one (1) tree for every ten (10) parking spaces, rounding up or down in the case of a fraction to the nearest whole number, and in no case should be less than one (1) tree. Required trees must be located in the interior of, or an area adjacent to the parking lot. For parking lots with more than 20 parking spaces, a minimum of five percent (5%) of the total interior parking lot area should be landscaped (excluding perimeter landscaping).

In addition to the parking lot tree requirements described above, shrubs should be planted along the perimeter of all parking surfaces so that the parking lot is screened from all adjacent public streets, exclusive of driveway entrances, pedestrian walkways and visibility triangles. Shrubs should be maintained at a height of no more than 36 inches or less than 18 inches as measured from the surrounding soil line. The number of shrubs required should be equal to the total number of street trees required multiplied by ten (10). No less than 75 percent of the shrubs required should be planted along the perimeter of the parking surface adjacent to the public street. A minimum 10'-0" wide landscaped area, exclusive of sidewalks and utility easements, should be provided between the parking lot and street right of way to accommodate the required screening shrubs.

### Design Requirements

Landscape islands should be created to comply with the above numerical requirements, to provide shade canopy and to break up the visual monotony of large asphalt covered areas. The requirements are as follows:

- Landscaped terminal islands should be provided at the end of each parking row. Terminal islands should contain at least one (2) trees and should be the approximate size of two (2) parking spaces.
- Additional intermediate islands should be created when the maximum number of parking spaces between terminal islands is greater than twenty (20). (Refer to Figure 18).

- All landscaped islands should be a minimum of 250 sq. ft.
- All landscaped islands should be provided with raised concrete curbs to prevent vehicular intrusion.

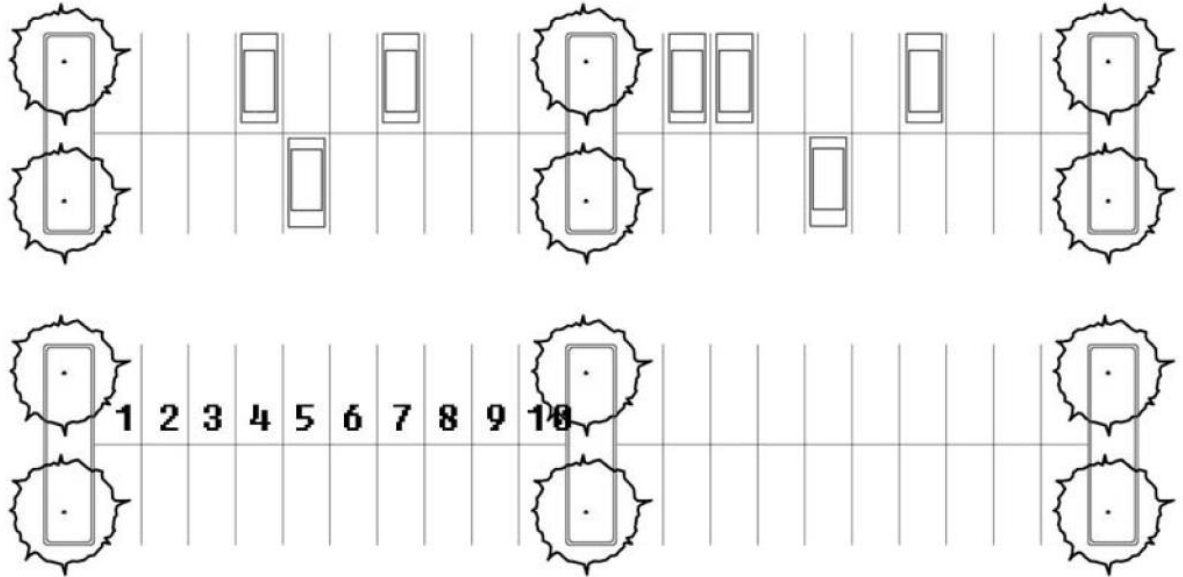

Figure 18 Parking Additional Intermediate Islands

#### Additional Considerations

- No tree should be planted closer than three (3) feet to a curb.
- All new trees should have a minimum caliper of 4” at installation.
- All required landscaped areas should be provided with a permanent and adequate means of irrigation and should be adequately maintained.
- Each island and screening buffer zone should be planted with ground cover or sodden lawn in addition to canopy trees.
- Large canopy shade trees are required for terminal islands and must be suitably sized, located and maintained to provide a clear trunk height of seven (7) feet at maturity to allow for unobstructed sight lines. A combination of canopy and ornamental trees that add color and variation may be planted in perimeter areas.
- Where canopy trees are located along the perimeter with screening shrubs, sight lines should be maintained between the underside of the canopy and the top of the shrubs for security. (Refer to Figures 19 and 20).

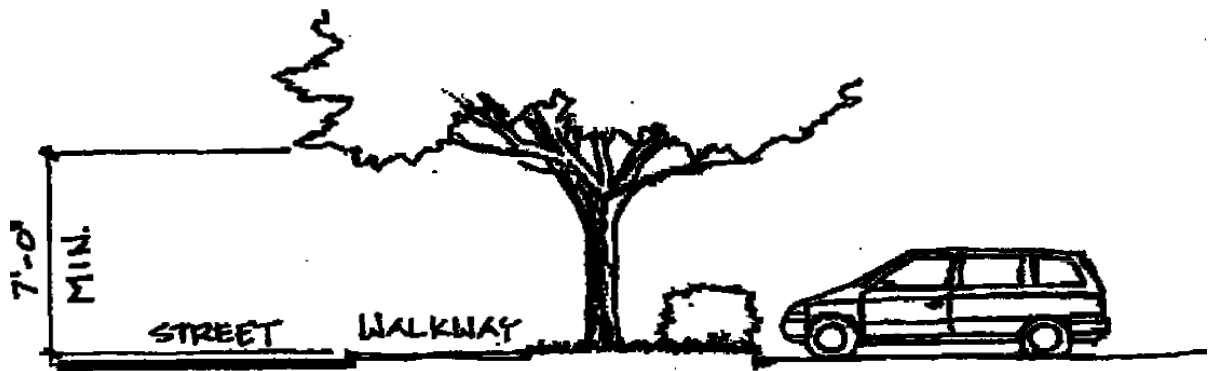

Figure 19 Minimum Clearance for Sight Lines

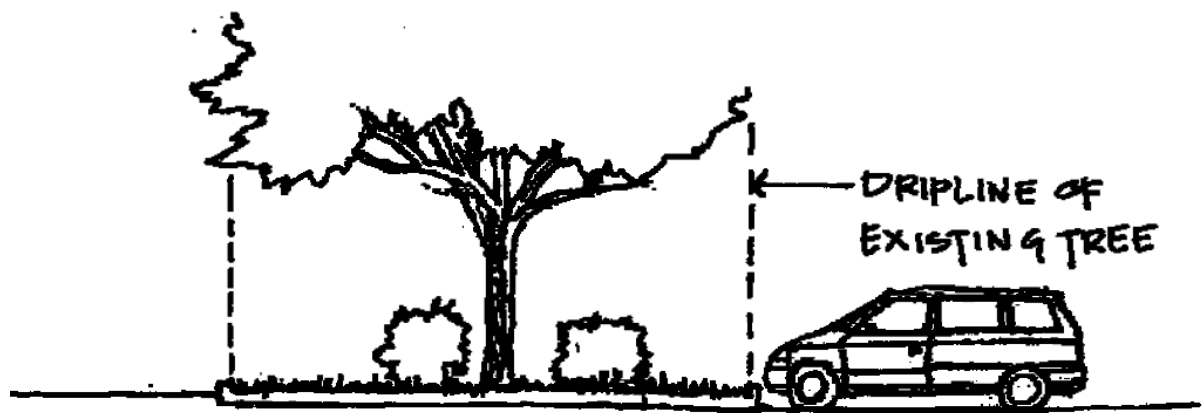

Figure 20 Vehicular Encroachment at Existing Trees

- All landscaping should be arranged so as not to obscure traffic signs or fire hydrants, or obstruct drivers' sight distance within the parking area and at driveway entrances.
- Preserve existing trees where possible, especially native species.
- No new parking lot or sidewalk paving or curbs should encroach within the drip line of existing trees. No equipment, dirt or construction materials should be stockpiled within the drip line of existing trees.

## Maintenance and Repair

### Introduction

All pavements require maintenance. They need this attention because stresses producing minor defects are constantly at work. These stresses may be caused by traffic loads, temperature fluctuations, or by changes in moisture content in the soil. Regardless of the cause, the result is the same. Without timely maintenance the pavement ultimately deteriorates. Preventive maintenance means the early detection and repair of minor defects, before major corrective action is necessary. It is the only proper way to care for a parking lot.

### Proper Drainage

For the maintenance of parking lots, moisture and drainage have three implications:

- First, a properly functioning drainage system can eliminate a number of future maintenance problems.
- Second, surface repair of a pavement defect caused by poor drainage will merely be a temporary solution, since it treats only the symptom, not the cause.
- Third, the most important repairs are those that will stop water from getting beneath the pavement surface. These repairs can prevent even larger maintenance expenditures in the future.

### Inspection and Evaluation

The key to successful maintenance is careful planning and programming of the work to be done. The first step in planning is a periodic evaluation of all parking areas and access roads in the system.

The parking lot should be thoroughly inspected at least twice a year for surface condition, structural strength, and drainage. The inspection should be done on foot rather than from a slow moving vehicle. This enables the inspector to notice very small cracks and defects. Subtle signs of future trouble, such as mud or water on the pavement, can be detected and recorded.

In all cases of pavement distress, it is important to determine the cause(s) of the difficulty. This will facilitate repairs that will both correct the defect and prevent its recurrence. Time and money spent for such repairs are well invested, since the same repairs will not have to be repeated in the future.

When the inspection has been completed, there should be a record of problem areas, as well as an idea of the general condition of the pavement. When these inspections reveal minor defects they should be repaired immediately, before they deteriorate into pavement failures requiring major maintenance expenditures.



Pavements in need of maintenance or repair can exhibit any or all of these conditions:

- *Raveling*: This is the progressive separation of aggregate particles in a pavement from the surface downward. Usually, the fine aggregate comes off first and leaves little "pock marks" in the pavement surface. As the process continues, larger and larger particles are broken free, and the pavement soon has the rough and jagged appearance typical of surface erosion. Raveling can result from lack of compaction during construction, construction during wet or cold weather, dirty or disintegrating aggregate, poor mix design, or extrinsic damage to the pavement.
- *Alligator Cracks*: These are interconnected cracks forming a series of small blocks resembling an alligator's skin or chicken wire. In most cases, alligator cracking is caused by excessive deflection of the surface over unstable subgrade or lower courses of the pavement. The unstable support usually is the result of saturated granular bases or subgrade. The affected areas are usually not large. They can cover entire sections of a pavement, and when this happens, it usually is due to repeated heavy loadings exceeding the strength of the pavement.
- *Upheaval*: Upheaval is the localized upward displacement of a pavement due to swelling of the subgrade or some portion of the pavement structure. Upheaval may also be caused by the swelling effect of moisture on expansive soils.
- *Pot Holes*: These are bowl-shaped holes of various sizes in the pavement, resulting from localized disintegration of the pavement under traffic. Contributory factors can be improper asphalt mix design, insufficient pavement thickness, or poor drainage. Also, potholes may simply be the result of neglecting other types of pavement distress.
- *Grade Depressions*: Depressions are localized low areas of limited size that may or may not be accompanied by cracking. They may be caused by traffic heavier than that for which the pavement was designed, by settlement of the lower pavement layers, or by poor construction methods. A depressed, cracked area frequently denotes a plastic failure in the base or subgrade. A cracked area without permanent deformation often indicates an elastic movement in the pavement structure.
- *Effects of Tree Roots*: This is either an upheaval situation in which the growth of the tree roots pushes the pavement up or a depression due to the trees removing moisture from the soils under the pavement. Treatment of these areas should be coordinated with the Campus Grounds Department.

## Corrective Actions

These are some typical cases of pavements requiring maintenance, and the proper methods of correcting the deficiencies.

*Pavement in Good Condition:* Typically, a pavement in good condition might exhibit fine cracking, and some raveling of the fine aggregate; the ordinary effects of some wear and tear. The remedy for this condition is the application of a light seal coat, such as a fog seal or an emulsified asphalt slurry seal. Seal coating should consist of two coats of coal tar asphalt sealer with eight pounds per gallon of concentrate sand aggregate and 5% latex additive. Seal coat should be allowed to cure for a minimum of 24 hours before re-stripping and marking. All newly paved lots should be seal coated within 12 months of completion and every three years thereafter to maximize the life of the pavement.

*Pavement in Fair Condition:* Such a pavement is characterized by random cracks of up to 13 mm (1/2 in.) in width, and raveled aggregate. Seal these cracks by:

- If needed, rout out the crack to the sealant manufacturers' specifications for width to depth ratio. Clean the crack using wire brushing, high-pressure air, sandblasting, hot air blasting, or high-pressure water. This is a key step to crack sealing or filling. If the crack is not thoroughly cleaned the sealant will not adhere to the sides. Thoroughly dry the crack before sealing.
- After removing the old sealant and/or cleaning the cracks, check them for depth. Generally, if they are over 19 mm (3/4 in.) deep, a backer rod is used to conserve sealant. The backer rod should be a compressible, non-shrinking, non-absorbent material with a melting point higher than the sealant temperature. The backer rod should be about 25% wider than the crack so it doesn't slip down, or float out after installing the sealant.
- Immediately before applying the sealant, inspect the cracks to ensure they are clean, dry and any backer material is properly installed. If the cracks have been left unsealed for any period of time, clean them out with compressed air before sealing them.
- The sealant should be applied from the bottom to the top of the crack to prevent air bubbles from forming and creating a weak spot in the sealant. Use a sealant kettle that has an injection wand for the best results. To prevent tracking the sealant should be left about 3 to 6 mm (1/8 to 1/4 in.) below the top of the crack. Use a squeegee to remove any excess sealant on the pavement surface.

*Pavement in Poor Condition:* This pavement may display random cracks, raveled aggregate, depressions, alligator cracks, potholes, and perhaps upheaval. Repairs these areas by:

- First, the areas of local distress -- areas containing alligator cracks, potholes, and upheavals -- should be repaired. This is accomplished by constructing a Full-Depth asphalt patch.
- Following the repair of local distress, cracks should be filled.
- Depressed areas should be restored to the proper cross-section by applying a leveling or wedge course. This is an asphalt layer of variable thickness, specifically intended to eliminate irregularities in the contour of an existing surface prior to an overlay.
- Finally, an asphalt overlay or slurry seal should be applied.

## **Section 6 — References**

- Highway Capacity Manual HCM. Transportation Research Board, National Research Council, Washington D.C., 2022.
- University of Houston, Campus Design Guidelines and Standards Parking Lot Design Standards.